

YUJUN METAL MESH

RAZOR WIRE
**INSTALLATION
GUIDANCE**

2022

7 STEPS FOR EASY AND QUICK RAZOR WIRE INSTALLATION

Before installing razor wire rolls, always wear your work cloth and safety goggles to avoid your hand being cut or hurt by razor blades.

STEP 1

Measure the length of the fence and calculate the number of razor wire rolls used. This depends on the type of razor blades. As the type of razor blade varies, the spacing between loops varies as well, therefore, the installation spacing of razor wire also varies accordingly.

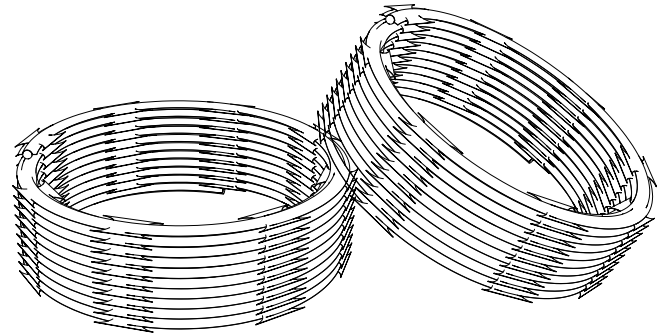

STEP 2

Attach two or more steel wires (barbed wires) to Y posts on both sides with tie wires or clips.

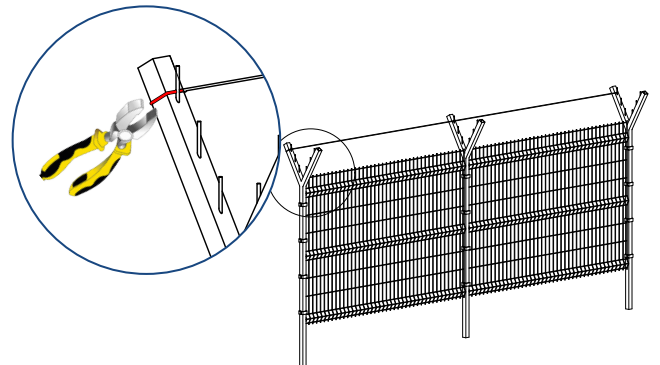

STEP 3

When all steel wires (or barbed wires) are installed, tension all support wires with a wire tensioner and make sure these wires are parallel to the base of the fence to support and fix razor wire.

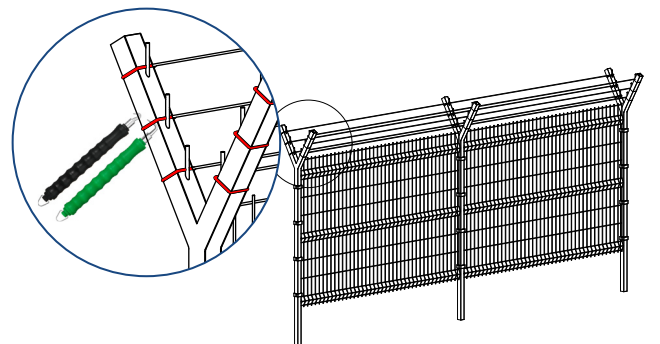

STEP 4

Place the razor wire roll in the starting point, secure razor wire loops to the Y posts and tension wires with tie wires or clips.

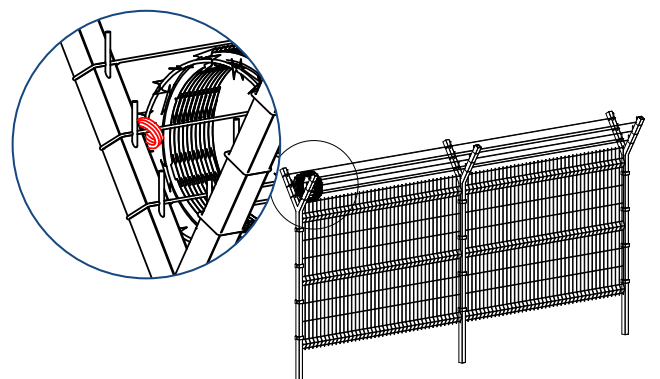

STEP 5

Distribute razor wire loops evenly at an interval of 25 cm (or preset loop spacing) from the starting point. When the first roll is installed to the end, connect the tail end of the first roll with the beginning point of the second roll with tie wires or clips, and then continue the installation.

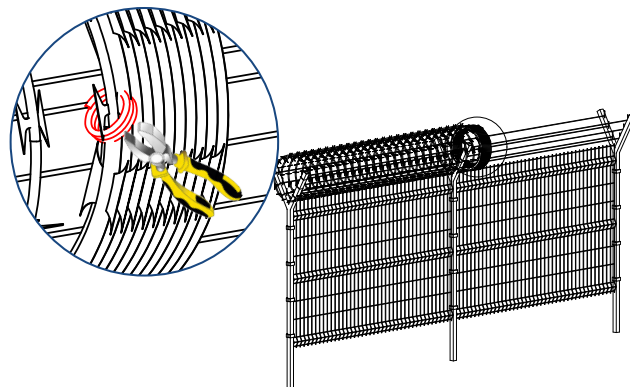

STEP 6

When all razor wire rolls are evenly distributed, secure the connections between razor wires, tension wires and the fence with tie wires to ensure that the razor wires are evenly distributed and firmly secured over the fence.

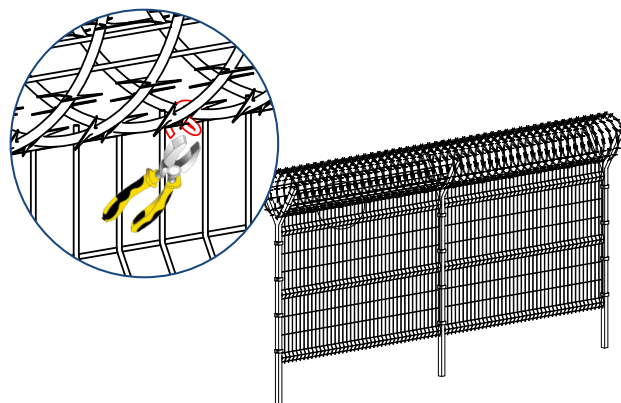

STEP 7

Razor wire installation is finished. Galvanized steel wires are recommended for tie wires as it has excellent corrosion resistance and more durable.

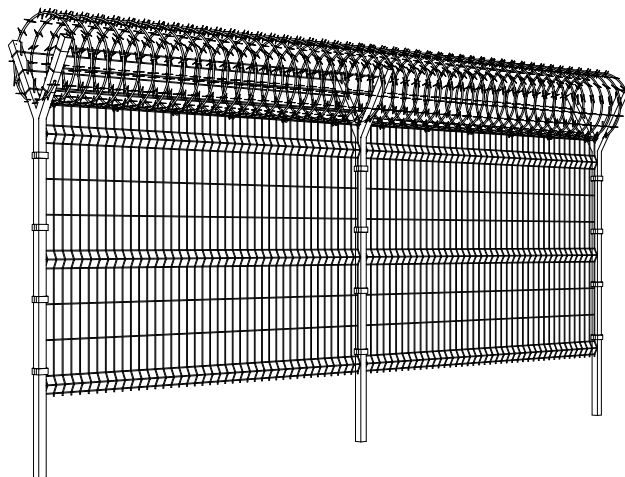

www.chinarazorwire.org

North Diwo Village, Donghuangcheng Town, Anping County,
Hengshui City, Hebei Province, China



+86-318-7595007



+86-13363329992



+86-13363329992



sales@chinarazorwire.org